

KTM700 RUS[®]

ULTRASONIC FLOW METER FOR CUSTODY TRANSFER
MEASUREMENT OF NATURAL GAS AND ASSOCIATED PETROLEUM GAS



APPLICATIONS

- Custody transfer of natural gas and associated petroleum gas
- Custody transfer of hydrogen and hydrogen-injected natural gas
- Measurement of regasified LNG at cryogenic temperatures
- Custody transfer gas at distribution stations

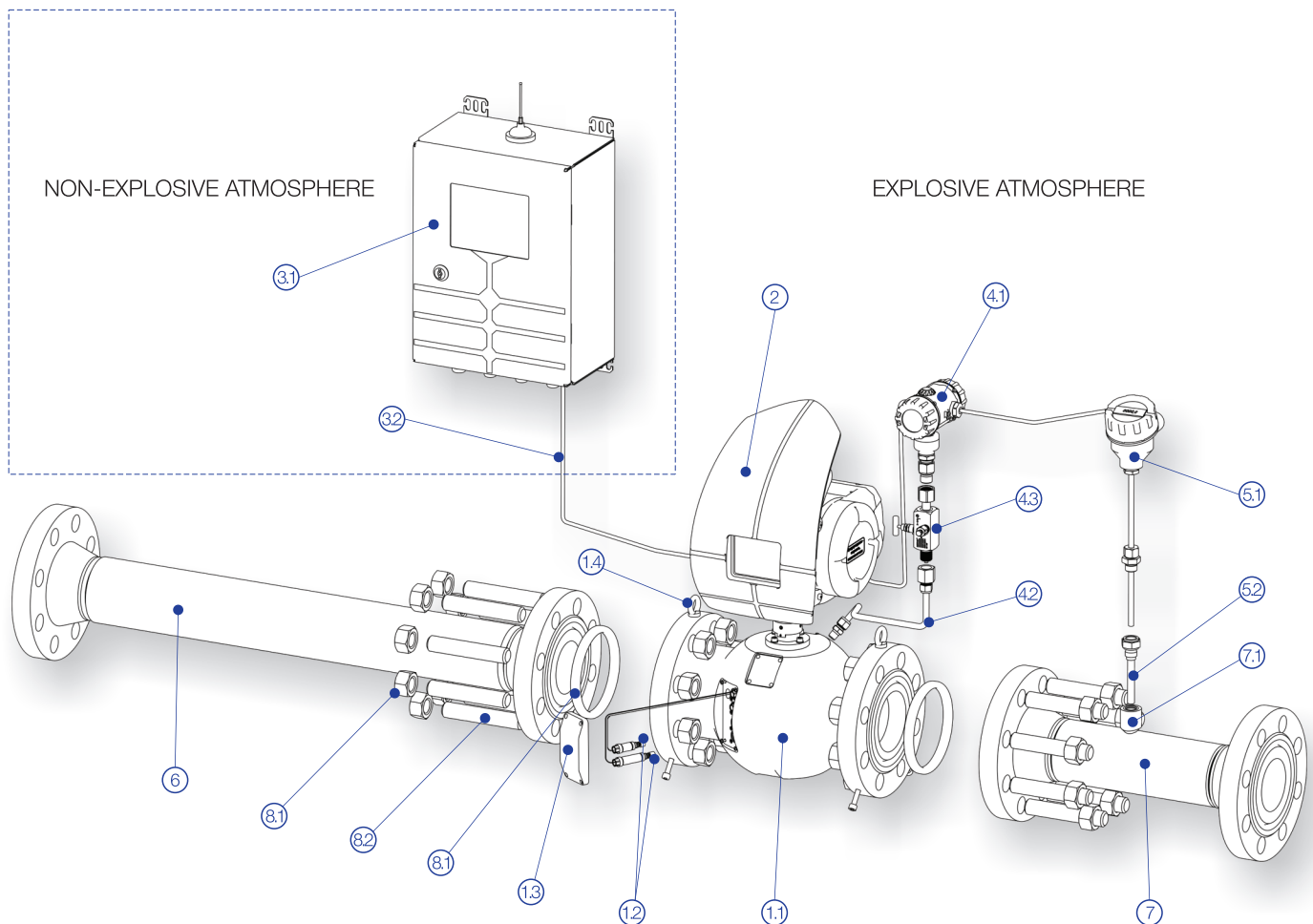

Description:

- meter body:
 - spool piece
 - set of ultrasonic transducers
 - cover
 - transportation bolts
- information processing unit (IPU)
- remote interface module:
 - remote module
 - connecting cable

Devices for measuring environmental parameters:

- pressure sensor
 - pressure transmitter
 - pressure tube
 - valve block
- temperature sensor
 - temperature transmitter
 - protective sleeve

Additional devices:

- straight inlet section 10DN (inlet section)
- straight outlet section 3DN (output section)
 - lug
- fasteners
 - gaskets
 - studs
 - nuts



ULTRASONIC FLOW METER FOR CUSTODY TRANSFER MEASUREMENT OF NATURAL GAS AND ASSOCIATED PETROLEUM GAS KTM700 RUS

- ✓ Our products are completely developed and manufactured in Russian Federation
- ✓ We have complete set of design and experimental data of our products that verify product quality
- ✓ We have own testing facilities that guarantee product precision and durability
- ✓ We have service centers across the world that can provide complete set of customer support
- ✓ We have robust production line that ensures shortest on-time product delivery to our customers

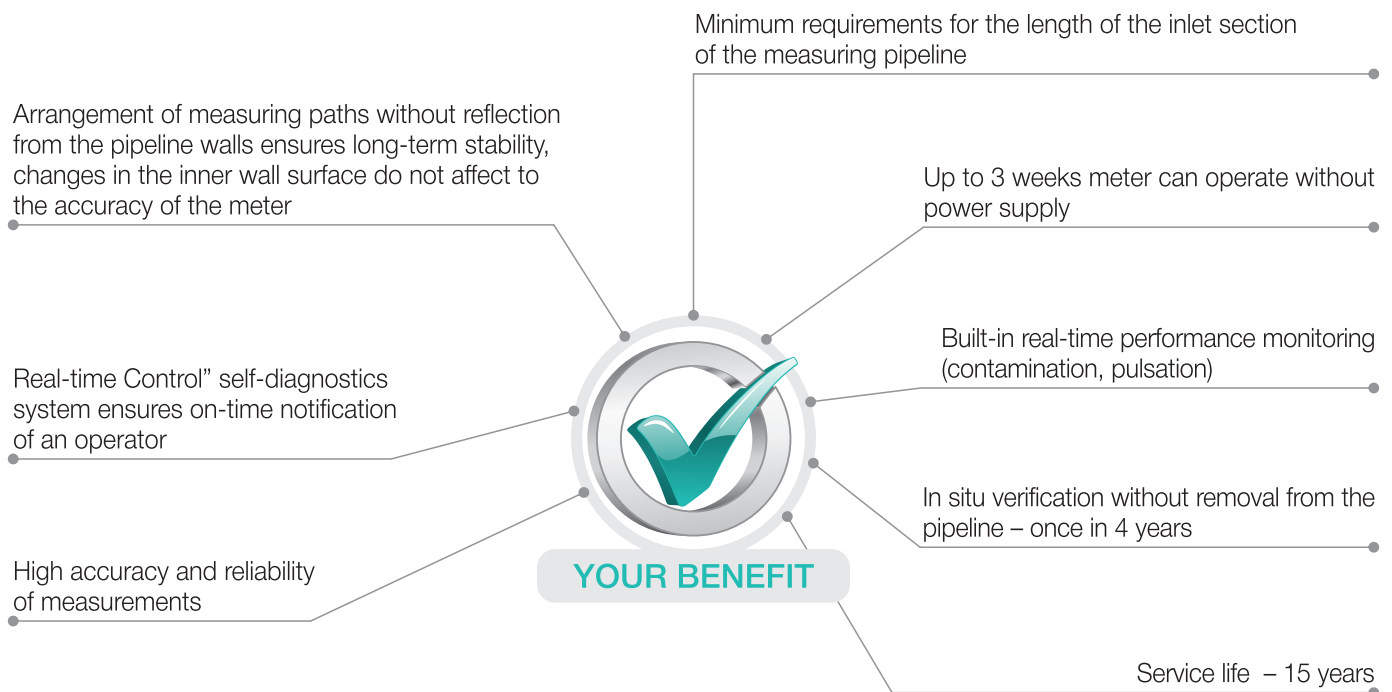



ULTRASONIC FLOW METER FOR CUSTODY TRANSFER MEASUREMENT OF NATURAL GAS AND ASSOCIATED PETROLEUM GAS KTM700 RUS

TECHNICAL DETAILS

Parameter name	KTM700 RUS	Notes
Nominal pipe diameter DN, mm	80 -1400	
Ambient temperature, °C	-40... +60	Extended range: -70 with thermal cover
Gas temperature, °C	-46... 180	Extended range: -194...330
Storage temperature, °C	-50...+60	
Operating pressure, bar	0... 280	Extended range: up to 450 bar
Number of measurement paths	4, 4x4, 4+1*, 4x3+1*	*- diagnostic path
Number of information processing units (IPU)	1,2*	*- on request
Ultrasonic transducer frequencies, kHz	80; 135; 200; 350	
I/O ports	1 output: 0/2/4 ... 22 mA, + 500 Ω According to NAMUR NE43 (Standardization Association for Measurement and Control)	
Analog outputs	2 inputs: 0...5/10 V or 0...20 mA Pulse/Frequency output (additional module)	
Analog inputs	3 outputs: 30 V DC/33 mA, max. frequency 10 kHz, outputs OC (Open collector) or NAMUR Status signals: normal operation/maintenance, service, and function control, range limit, maintenance needed	
Digital outputs	1 digital input, 30 V DC/33 mA	
Digital inputs	USB (optional) RS485 - standard Ethernet (optional)	
USB/Serial ports	4-20mA/HART, RS485/MODBUS RTU/ASCII, Ethernet/MODBUS TCP, PROFIBUS DP/PA, Foundation Fieldbus	
Optional output signals		
Ex approvals		
-IPU;	IP66/IP67	
-Interface module	IP54	
Supply voltage, V	12...30	
Power consumption, Watt	< 6	

METROLOGICAL PARAMETERS OF THE METER

Parameter name	Error limit, %
Volume flow rate measurement error limit o.c., %	
$Q_{min} < Q < Q_t$	±1,0
$Q_t < Q < Q_{max}$	±0,3

STANDARD SIZES OF THE METER AND CORRESPONDING FLOW RATES WITH RESPECTIVE GAS VELOCITIES

Meter diameter	Gas flow rate at o.c., m ³ /h			Gas velocity, m/s	
	Q_{min}	Q_t	Q_{max}	V_t	V_{max}
DN80	5	40	1000	1.5	61
DN100	8	65	1600	1.5	63
DN150	16	100	3000	1.5	52
DN200	20	160	4500	1.5	44
DN250	25	240	7000	1.5	44
DN300	35	310	8000	1.5	39
DN350	45	420	10000	1.5	36
DN400	60	550	14000	1.5	38
DN450	100	700	17000	1.5	37
DN500	130	850	20000	1.5	35
DN550	150	1000	24000	1.5	35
DN600	180	1200	32000	1.5	39
DN650	240	1400	35000	1.5	36
DN700	280	1700	40000	1.5	36
DN750	320	1900	45000	1.5	35
DN800	360	2200	50000	1.5	34
DN850	400	2500	55000	1.5	33
DN900	450	2800	66000	1.5	36
DN950	500	3100	70000	1.5	34
DN1000	550	3400	80000	1.5	35
DN1050	600	3800	85000	1.5	34
DN1100	650	4100	90000	1.5	32
DN1150	700	4500	95000	1.5	34
DN1200	750	4800	100000	1.5	30
DN1300	900	5600	110000	1.5	28
Dn1400	1000	6500	120000	1.5	27